

“DCVA” AND “DCVAM” SERIES CONTROL VALVES

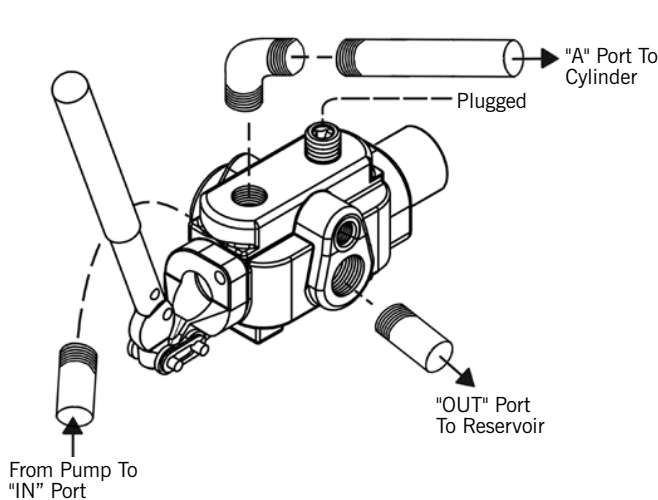

MODELS DCVA-100, DCVAM-100

3-way control valve designed to operate a one-way hydraulic circuit from a single hydraulic source.

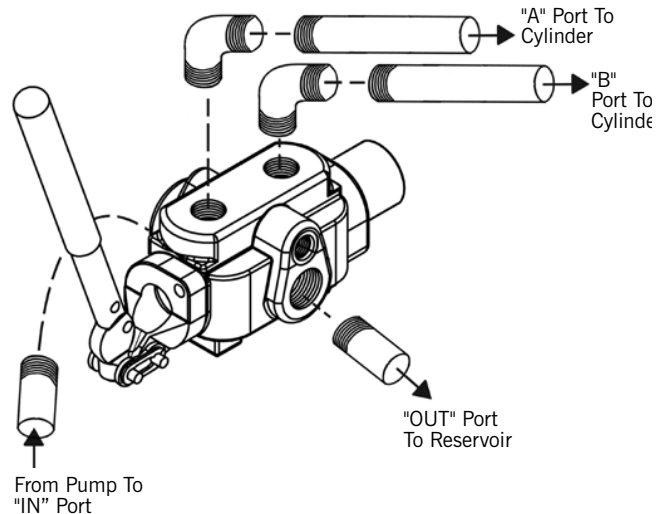

MODELS DCVA-200, DCVAM-200

4-way control valve designed to operate a two-way hydraulic circuit from a single hydraulic source.

SINGLE ACTING USE (MODEL DCVA-100 & MODEL DCVAM-100) & DOUBLE ACTING USE (MODEL DCVA-200 & MODEL DCVAM-200) INSTALLATION:

CAUTION: CONTAMINATION – Energy strongly recommends the use of a hydraulic filter in your system to reduce the risk of malfunction due to contamination. The clearances between the valve spool and body are very small and contamination may bind the spool or damage parts from scoring.

WARNING: LOAD LIFTING – DCVA valves do not contain load check valves and therefore should not be used in lifting applications unless some other means of holding the load is provided.

WARNING: Do not modify any parts of this valve. **SERIOUS INJURY COULD RESULT IF VALVE FUNCTION IS ALTERED.**

WARNING: If the valve spool binds and will not move freely – **DISCONTINUE USE.**

WARNING: Do not use these valves on applications where property damage or personal injury may result from a lack of positive control. There are no check valves to prevent load dropping while changing spool positions or to prevent slow drift of a cylinder or motor.

WARNING

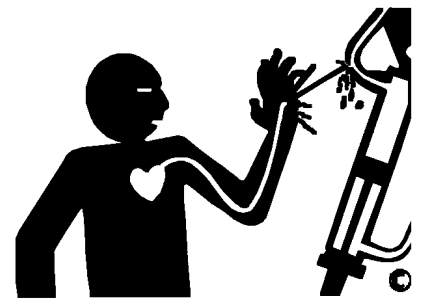

DO NOT GO NEAR LEAKS

- High pressure oil easily punctures skin causing serious injury, gangrene or death.
- If injured, seek emergency medical help. Immediate surgery is required to remove oil.
- Do not use finger or skin to check for leaks.
- Lower load and relieve hydraulic pressure before loosening fittings.

“DCVA” AND “DCVAM” SERIES CONTROL VALVES



WARNING – Before installing product, read and understand all warnings, safety labels and instructions. Failure to do so could result in **SERIOUS INJURY!**

1. Install control lever as shown in drawing.
2. Mount valve using 3/8”-16NC tapped holes in the base of valve. **CAUTION:** Mounting valve to uneven mounting plate may cause the valve body to distort and the valve spool to bind. Move the control lever during the tightening procedure to assure that the valve spool does not lock or bind as a result of the tightening. Exerting heavy pressure on the control lever should be avoided as it may cause valve damage. **IF THE VALVE SPOOL BINDS IN ANY WAY, DISCONTINUE USE AND CALL FACTORY.**
3. Make port connections as shown in drawing. (NOTE: We do not recommend the use of Teflon tape because of potential contamination to the hydraulic system.) **CAUTION:** Excess tightening of the port fittings may cause the valve body to distort and the valve spool to bind. Move the control lever during the tightening procedure to assure the valve spool does not lock or bind as a result of the tightening. **IF THE VALVE SPOOL BINDS IN ANY WAY, DISCONTINUE USE AND CALL FACTORY.**
4. CONTROL LEVER LOCATION: The control valve is designed so that the lever may be located on the opposite end of the valve if desired. To do this, proceed as follows:
 - (a) Remove all parts from both ends of valve.
 - b) Push valve spool out of valve body and remove seal retainer, back-up washer, and O-ring seal at each end of valve body.
 - (c) Turn valve spool end-for-end and replace in valve body.
 - (d) Install O-ring seal, back-up washer, and seal retainer in end of valve body.
 - (5) Reassemble per pictorial of valve and parts list.

The internal relief valve is factory set to 2,000 PSI (138 bar) ± 200 PSI (14 bar) at 10 GPM (38 lpm) Adjustment can be made by removing the relief valve plug and by turning the slotted or hex-keyed adjustment screw clockwise to increase the pressure and counterclockwise to decrease the pressure. Pressure range is 400 PSI (28 bar) to 2,500 PSI (172 bar) at 10 GPM (38 lpm). **PRESSURE ADJUSTMENTS SHOULD NEVER BE MADE WITH THE PUMP OPERATING AND THE RELIEF VALVE SETTING MUST BE MEASURED WITH A PRESSURE GAUGE TEED TO THE VALVE “IN” PORT.**

INSTRUCTIONS FOR REPLACING THE VALVE SPOOL SEALS

1. Remove all parts from both ends of valve.
2. Remove valve spool from valve body and remove seal retainer, back-up washer, O-ring seal at each end of valve body.
3. Replace valve spool into housing.
4. Install new O-ring seal, back-up washer, and original seal retainer in each end of valve body.
5. Reassemble per pictorial of valve and parts list.

NOTE: CONTROL LEVER ASSEMBLY CONSISTS OF ITEMS MARKED WITH ** TORQUE MOUNTING SCREWS (ITEM 15) TO 70-90 IN.-LBS.

NOTE: SEPARATE EARS ON COTTER PIN (ITEM 9) AFTER INSTALLING

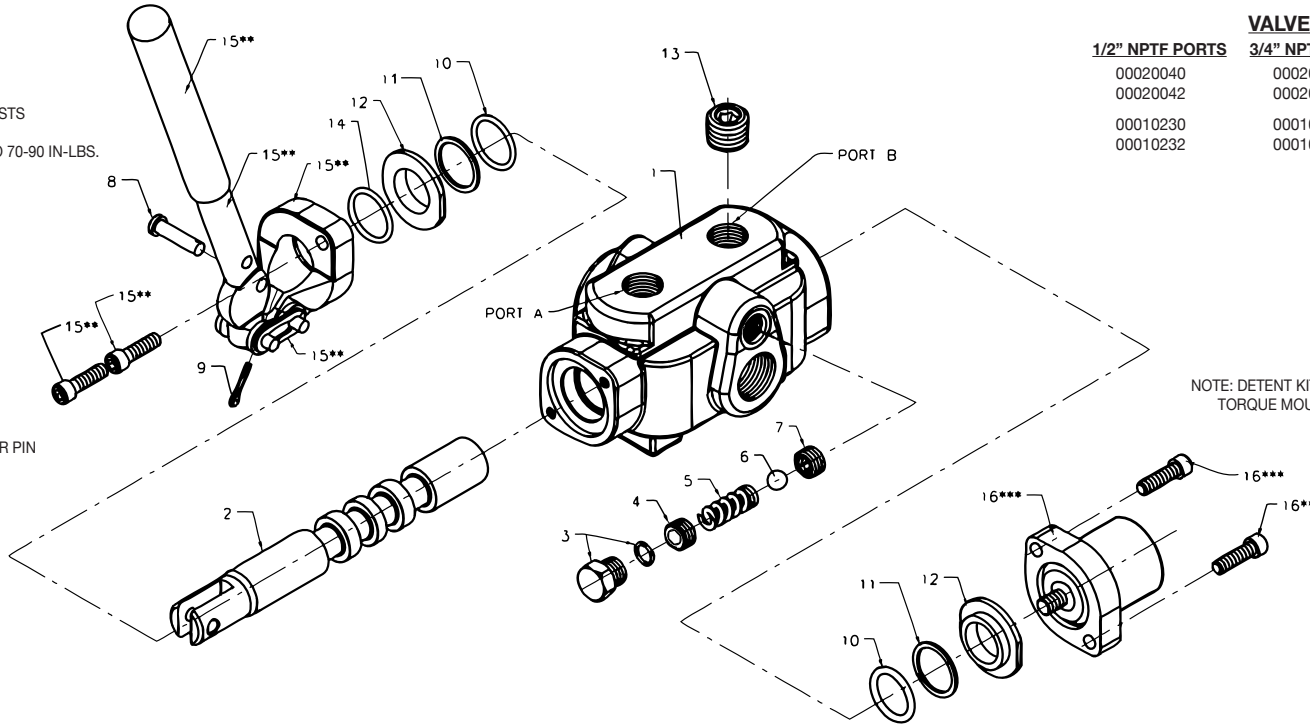

NOTE: DETENT KIT CONSISTS OF THE ITEMS MARKED WITH *** TORQUE MOUNTING SCREWS (ITEM 16) TO 70-90 IN.-LBS.

VALVE PART NUMBERS

1/2" NPTF PORTS	3/4" NPTF PORTS	DESCRIPTION
00020040	00020041	MODEL DCVA-100 (3-WAY)
00020042	00020043	MODEL DCVA-200 (4-WAY)
00010230	00010231	MODEL DCVAM-100 (3-WAY)
00010232	00010233	MODEL DCVAM-200 (4-WAY)

ITEM NO.	PART NO.	NAME	QTY.
1	0C000737	CONTROL VALVE BODY (1/2" NPTF CYLINDER PORTS).....	1
	0C000738	CONTROL VALVE BODY (3/4" NPTF CYLINDER PORTS).....	1
2	0B002709	VALVE SPOOL (FOR MODEL DCVA-100).....	1
	0B002708	VALVE SPOOL (FOR MODEL DCVA-200).....	1
	0B002783	VALVE SPOOL, 4-WAY, OPEN CENTER MOTOR (FOR DCVAM-200).....	1
	0B003449	VALVE SPOOL, 3-WAY, OPEN CENTER MOTOR (FOR DCVAM-100).....	1
3	00082527	O-RING BOSS PLUG W/O-RING.....	1
4	00082515	SLOTTED OR HEX-KEYED ADJUSTMENT SCREW.....	1
5	19985A	RELIEF VALVE SPRING ASSEMBLY.....	1
6	19282A	STEEL BALL.....	1
7	19902A	VALVE SEAT.....	1
8	00080409	CLEVIS PIN.....	1
9	00080414	COTTER PIN.....	1
10	00080311	O-RING.....	2
11	00082131	BACK-UP RING.....	2
12	0A004912	SEAL RETAINER.....	2

ITEM NO.	PART NO.	NAME	QTY.
13	00080649	1/2" NPTF PIPE PLUG, HEX. SOC. (DCVA-100, DCVAM-100).....	1
	00080650	3/4" NPTF PIPE PLUG, HEX. SOC. (DCVA-100, DCVAM-100).....	1
14	00080311	O-RING 7/8" I.D. x 1-1/16" O.D. (OPTIONAL).....	1
15	0A002851	CONTROL LEVER ASSEMBLY.....	1
		CONSISTS OF:	
		0B005146 HANDLE.....	1
		0A002900 GRIP.....	1
		00082832 CHAIN LINK.....	1
		26264B CONTROL LEVER BRACKET AND SCREWS.....	1
16	36578B	DETENT KIT W/SCREWS (ALL POSITIONS DETENT).....	1
	36577B	DETENT KIT W/SCREWS (DETENT WHEN VALVE SPOOL IS PULLED FROM VALVE BODY).....	1
	36561B	DETENT KIT W/SCREWS (DETENT WHEN VALVE SPOOL IS PUSHED INTO VALVE BODY).....	1
-	0A000487	SEAL KIT (CONTAINS ALL SEALS USED IN VALVE)	